



## Power Oscillation Damping by Using SSSC with and Without Pod Controller in Electrical Power Transmission System

**Gourav Sitole**

*M.E. Research Scholar,  
(High Voltage Engineering)  
Jabalpur Engineering College  
Jabalpur, (M.P.) [INDIA]  
Email: [gourav2sitole@gmail.com](mailto:gourav2sitole@gmail.com)*

**Arun Pachori**

*Associate Professor  
Department of Electrical Engineering  
Jabalpur Engineering College  
Jabalpur, (M.P.) [INDIA]  
Email: [arunpachori11@gmail.com](mailto:arunpachori11@gmail.com)*

### ABSTRACT

*As a result of the potential of power electronic shift devices management and high speed, additional benefits have in FACTS devices areas and presence of those devices in transient stability throughout transient faults leading to improvement in grid stability. During this paper, review of technique a Static Synchronous Series compensator (SSSC) is employed to review the impact of this device in dominant active and reactive powers still as damping of power oscillations in transient mode. Simulation result shows the accuracy of planned compensator and achieving the required price for active and reactive powers, and damping of oscillations.*

**Keywords:**— Cable, Power oscillation damping, Static Synchronous Series compensator (SSSC), Active and Reactive power

### I. INTRODUCTION

Series compensation may be suggests that of dominant the facility transmitted across transmission lines by sterilization or dynamic the characteristic electrical phenomenon of the road [20]. the facility flow downside is also associated with the length of the line. The line is also stipendiary by a hard and fast electrical device or inductance to satisfy the wants of

the transmission. once the structure of the transmission network is taken into account, power flow imbalance issues arise. unintended interchange happens once the facility system tie line becomes corrupted. this can be owing to surprising amendment in load on a distribution feeder because of that the demand for power on it feeder will increase or decreases. The generators square measure to be turned on or off to catch up on this alteration in load. If the generators don't seem to be activated terribly quickly, voltage sags or surges will occur [18]. In such cases, controlled series compensation helps effectively.

### *Single-Line Diagram of a SSSC and Its Control System Block Diagram*

The Static Synchronous Series Compensator (SSSC) is a series device of the Flexible AC Transmission Systems (FACTS) family using power electronics to control power flow and improve power oscillation damping on power grids [1]. The SSSC is injects a voltage  $V_s$  in series with the transmission line where it is connected. Figure 2 shows single line diagram of SSSC transmission system and its control structure. As the SSSC does not use any active power source, the injected voltage must stay in quadrature with line current. By varying the magnitude of the injected

voltage  $V_q$  in quadrature with current, the SSSC performs the function like a variable reactance compensator either capacitive or inductive [11]. The variation in injected voltage is performed by means of a Voltage-Sourced Converter (VSC) that is connected on the secondary side of a coupling transformer. The Voltage-Sourced Converter (VSC) uses forced commutated power electronic devices (GTOs or IGBTs) to synthesize a voltage  $V_{conv}$  from a DC voltage.

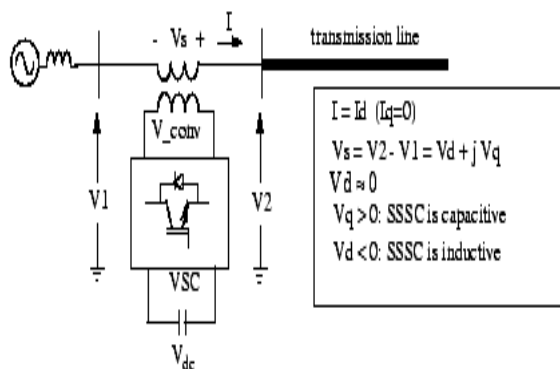

Figure 1: Single-line Diagram of a SSSC.

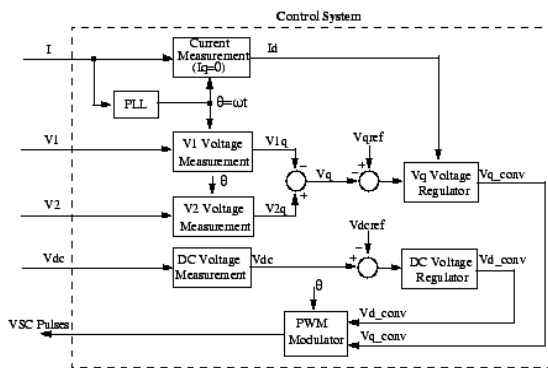

Figure 2: System Diagram of a SSSC.

A capacitance connected on the DC aspect of the VSC acts as a DC voltage supply. during this period low active power drawn from the road to stay the capacitance charged and supply to electrical device, in order that the injected voltage  $V_s$  is much ninety degrees out of part with current  $I$ . the system diagram  $V_{dconv}$  and  $V_{qconv}$  selected the elements of convertor voltage  $V_{conv}$  that square measure severally in part

and in construction with current [12]. VSC victimization GTO-based square-wave inverters and special interconnection transformers. during this system generally four three-level inverters square measure wont to build a 48-step voltage wave form. Special interconnection transformers technique square measure won't to neutralize harmonics contained within the sq. waves generated by individual inverters. during this Voltage- Sourced convertor (VSC), the basic element of voltage  $V_{conv}$  is proportional to the voltage  $V_{dc}$ . this kind of electrical converter uses Pulse-Width Modulation (PWM) technique to synthesize a curved wave form from a DC voltage with a typical chopping frequency of a couple of kHz. Harmonics square measure eliminating by connecting filters at the AC aspect of the VSC. This kind of VSC uses a hard and fast form of DC voltage  $V_{dc}$ . Voltage  $V_{conv}$  is varied by dynamic the modulation index of the PWM modulator [15].

### The System of SSSC Consists

A phase-locked loop (PLL) that synchronizes on the positive-sequence element of the present  $I$ . The output of the PLL (angle  $\theta = \omega t$ ) is employed to reason the direct-axis and quadrature-axis elements of the AC three-phase voltages and currents (labeled as Cupid's disease,  $V_q$  or  $I_d$ , intelligence quotient on the diagram) [17]. Measurement systems activity the alphabetic character elements of AC positive-sequence of voltages  $V_1$  and  $V_2$  ( $V_{1q}$  and  $V_{2q}$ ) further because the DC voltage  $V_{dc}$ . AC and DC voltage regulators that reason the 2 elements of the convertor voltage ( $V_{dconv}$  and  $V_{qconv}$ ) needed getting the required DC voltage ( $V_{dref}$ ) and also the injected voltage ( $V_{qref}$ ). The  $V_q$  transformer is power-assisted by a feed forward sort regulator that predicts the  $V_{conv}$  voltage from the  $I_d$  current measure.

**Comparison of Series Compensator Types**

Figure 3 shows a comparison of VI and loss characteristics of variable type series compensators and the converter based series compensator.

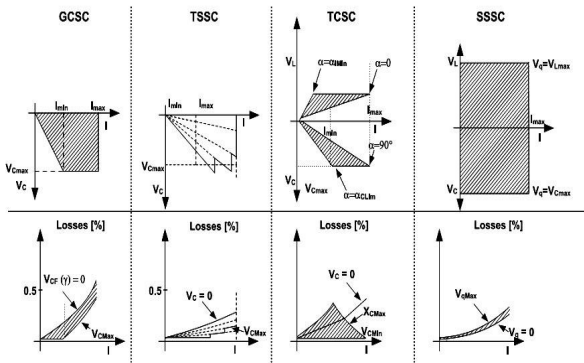

Figure 3: Comparisons of Variable Type Series Compensators to Converter Type Series Compensator [8]

From the figure the following conclusions can be made.

The SSSC is capable of internally generating a controllable compensating voltage over any capacitive or inductive range independent of the magnitude of the line current. The GCSC and the TSSC generate a compensating voltage that is proportional to the line current. The TCSC maintains the maximum compensating voltage with decreasing line current but the control range of the compensating voltage is determined by the current boosting capability of the thyristor controlled reactor.

The SSSC has the ability to be interfaced with an external dc power supply. The external dc power supply is used to provide compensation for the line resistance. This is accomplished by the injection of real power as well as for the line reactance by the injection of reactive power. The variable impedance type series compensators cannot inject real power into the transmission line. They can only provide reactive power compensation.

The SSSC with energy storage can increase the effectiveness of the power oscillation damping by modulating the amount of series compensation in order to increase or decrease the transmitted power. The SSSC increases or decreases the amount of transmitted power by injecting positive and negative real impedances into the transmission line. The variable-type series compensators can damp the power oscillations by modulating the reactive compensation.

**Static Synchronous Series Compensator (SSSC)**

The Voltage Sourced Converter (VSC) based series compensators - Static Synchronous Series Compensator (SSSC) was proposed by Gyugyi in 1989. The single line diagram of a two machine system with SSSC is shown in Figure 4 The SSSC injects a compensating voltage in series with the line irrespective of the line current [19]. From the phasor diagram, it can be stated that at a given line current, the voltage injected by the SSSC forces the opposite polarity voltage across the series line reactance. It works by increasing the voltage across the transmission line and thus increases the corresponding line current and transmitted power.

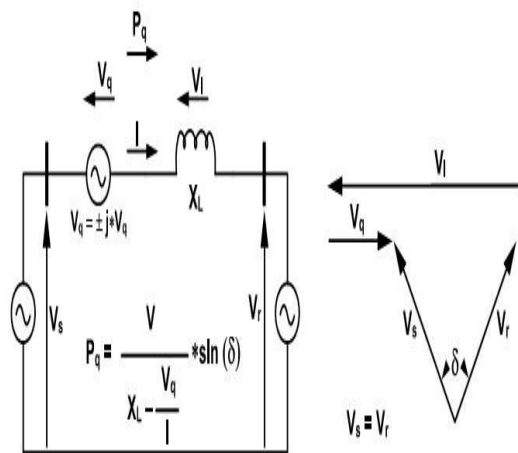

Figure 4: Simplified Diagram of Series Compensation with the Phasor Diagram. [11]

The compensating reactance is defined to be negative when the SSSC is operated in an inductive mode and positive when operated in capacitive mode. The voltage source converter can be controlled in such a way that the output voltage can either lead or lag the line current by 90°. During normal capacitive compensation, the output voltage lags the line current by 90°. The SSSC can increase or decrease the power flow to the same degree in either direction simply by changing the polarity of the injected ac voltage. The reversed (180°) phase shifted voltage adds directly to the reactive voltage drop of the line. The reactive line impedance appears as if it were increased. If the amplitude of the reversed polarity voltage is large enough, the power flow will be reversed. The transmitted power versus transmitted phase angle relationship is shown in Equation 1 and the transmitted power versus transmitted angle as a function of the degree of series compensation is shown in Figure 5.

$$P = \frac{V^2}{X} \sin \delta + \frac{V}{X} V_q \cos \frac{\delta}{2} \dots\dots\dots(1)$$

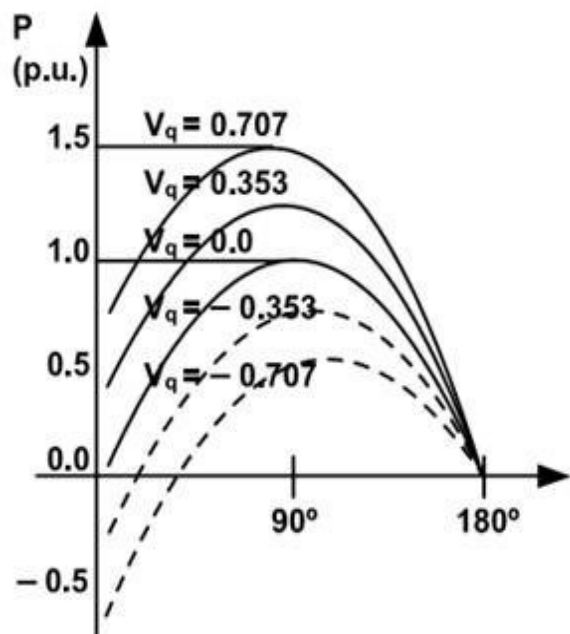

Figure 5: Transmitted power versus transmitted angle as a function of series compensation [12]

## II. METHODOLOGY

A Static Synchronous Series compensator (SSSC) is a member of FACTS family which is connected in series with a power system. It consists of a solid state Voltage Source Converter (VSC) which generates a controllable alternating current and voltage at fundamental frequency. When the voltage injected is kept in quadrature with the line current, it can follow as inductive or capacitive reactance so as to influence the power flow through the transmission line [11]. While the primary purpose of a SSSC is to control power flow in steady state and also improve transient stability of a power system. A Static Synchronous Series compensator (SSSC) is used to investigate the effect of this device in controlling active and reactive powers as well as damping power system oscillations in transient mode. The SSSC set with a source of energy in the DC link can supply or absorb the reactive and active power from or to the line. Simulations have been done in MATLAB/SIMULINK environment. Simulation results shows for selected bus-2 in three phase 500 KV transmission line system shows the accuracy of this compensator [17]. FACTS devices member in controlling power flows, achieving the desired value for reactive and active powers, and damping oscillations appropriately. The methodology of this paper is shown in the figure 6 with the help of simulink diagram representation. The description of each block in the above figure is as follows:

1. **Three Phase Source** – The three phases block supplies 500KV three phase voltage to the transmission line.
2. **Three phase fault generator**– this block generator fault on the transmission line according to user specification.



3. **B1 Bus**– this bus indicates interfacing connection between 500 KV 2100 MVA source and SSSC block and also provides Voltage(V) & Current (I) measurement.
4. **Static Synchronous Series Compensator (SSSC) block** –this block represents the SSSC simulation model for the project work.
5. **B2 Bus**– this bus indicates interfacing connection between SSSC block and 280 KM line and also provides Voltage(V), Current(I) measurement. **280 Km Line** – this block represents 280 KM transmission line.
6. **Three Phase Dynamic Load** – represents load at the end of transmission side.
7. **150 Km Line** – this block represents 150 KM transmission line.
8. **B4 Bus**- this bus indicates interfacing connection between 150 KM line to next 150 KM line.
9. **B3 Bus**- this bus indicates interfacing connection between 50 KM line and dynamic load.

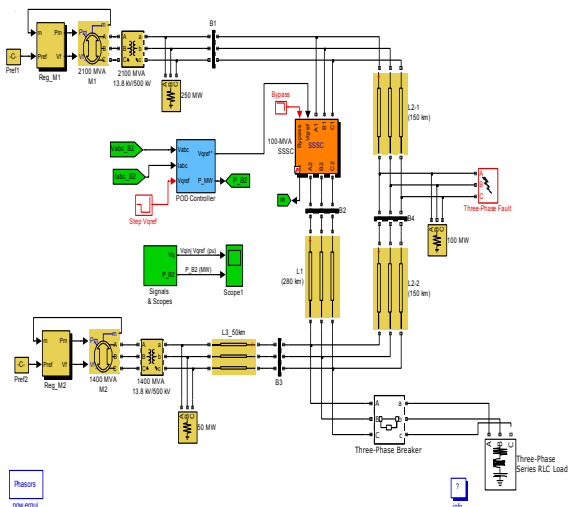

Figure 6: Simulink Diagram Representation of Proposed Work.

### III. RESULTS AND DISCUSSIONS

SSSC damping power oscillation while not POD controller.

Under this condition disable the Vqref variations. And “Switching of section A, B and C” to simulate a three-phase fault. The transition times ought to be set as follows:

1. The fault are applied at one. 33s and can last for ten cycles.
2. At this condition “Maximum rate of amendment for Vqref (pu/s)” is three.

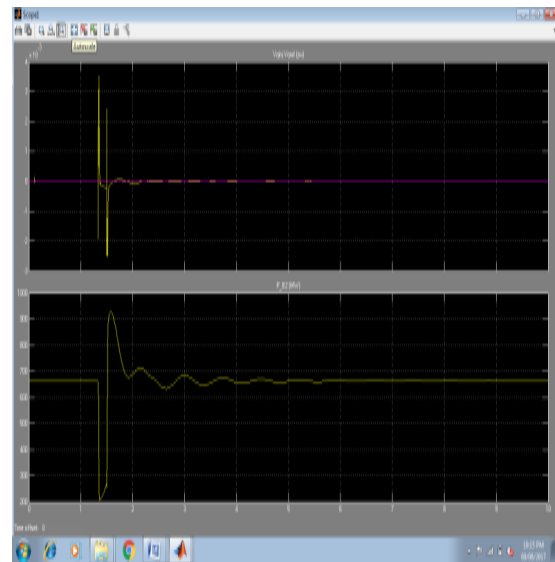

Figure 7 : illustrates, the facility obtained at bus B2 while not SSSC.

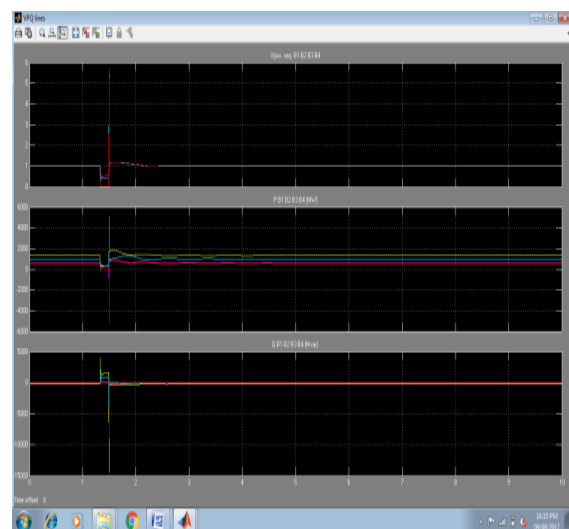

Figure 8: Shows the power obtained at all the buses B1, B2, B3 and B4 without SSSC.

### SSSC Damping Power Oscillation with POD Controller.

Under this condition disable the Vqref variations. And "Switching of phase A, B and C" to simulate a three-phase fault. The transition times should be set as follows:

1. The fault will be applied at 1.33 s and will last for 10 cycles.
2. At this condition "Maximum rate of change for Vqref (pu/s)" is 3.

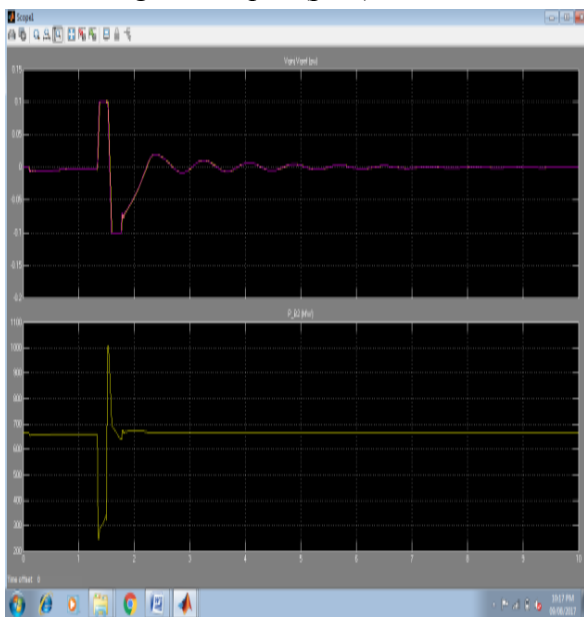

Figure 9: Illustrates, the Power Obtained at Bus B2 without SSSC.

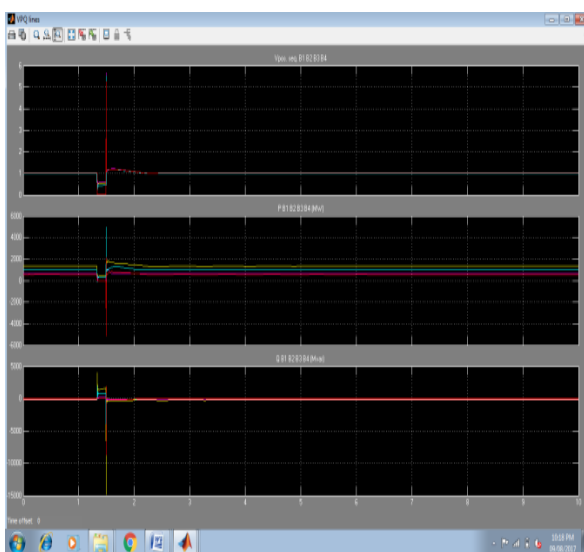

Figure 10: Shows the Power Obtained at all the Buses B1, B2, B3 and B4 without SSSC.

Now let us consider the SSSC in the same transmission line system with same amount of three phase fault. The power obtained at bus B2 with SSSC is shown in figure 7. Figure 8 shows the power obtained at all the buses B1, B2, B3, and B4 with SSSC structure. Figure 9 shows the reference voltage and modified reference voltage by reference voltage controller. Finally figure 10 shows the plot of reference voltage and injected voltage by SSSC. From the resultant figures it is clear that the SSSC with reference voltage controller provides good damping for power oscillation.

### IV. CONCLUSION

Complete Simulations have been done in MATLAB/SIMULINK environment. Simulation results shows of selected bus-2 in three phase 500 KV transmission line system shows the accuracy of this compensator as one of the FACTS devices member controlling power flows, achieving the desired value for active and reactive powers, and also damping oscillations appropriately. The result section provides complete idea about the power oscillation damping capability of the SSSC. Moreover the system developed is able to provide damping for power oscillations, but still this system demands further improvement for higher damping during power oscillation.

### REFERENCES:

- [1] N. G. Hingorani and L. Gyugyi, "Understanding FACTS concepts and Technology of flexible AC transmission systems", New York. IEEE Press, 2000.
- [2] E.Acha., H Ambriz-Perez and Fuerte-Esquivel "Advanced SVC Models for Newton-Raphson Load Flow and Newton Optimal Power Flow Studies", IEEE Transactions on

- Power Systems, Vol. 15(1), p.129-136, 2000.
- [3] L Cai “ Robust Co-ordinated Control of FACTS Devices in Large Power Systems” a PhD Thesis, University of Duisburg, Germany, published by Logos Verlag Berlin, 2004.
- [4] T. Orfanogianni and R. Bacher. “Steady-state optimization in power systems with series FACTS devices”, IEEE Transactions on Power Systems, Vol. 18(1), pp.19–26, 2003.
- [5] B.H. Kim and R. Baldick. “A comparison of distributed optimal power flow algorithms”, IEEE Transactions on Power Systems, Vol. 15(2), pp. 599–604, 2000. International Journal of Engineering Research & Technology
- [6] B. Singh, K.S. Verma, P. Mishra, R. Maheshwari, U. Srivastava and A. Baranwal, “Introduction to FACTS Controllers: A Technological Literature Survey”, International Journal of Automation and Power Engineering, Volume 1 Issue 9, website: [www.ijape.org](http://www.ijape.org) December 2012
- [7] Bhaskaraiah and G. U. Reddy, “Power system stability enhancement using static synchronous series compensator(SSSC)”, International Journal of Electrical, Electronic and Telecommunications, ISSN 2319 – 2518, [www.ijeetc.com](http://www.ijeetc.com), Vol. 2, No. 1, January 2013
- [8] M. Ahsan, A. Murad, F. J. Gómez and L. Vanfretti, “Equation-Based Modeling of FACTS using Modelica”, July 2013
- [9] E. Acha, C. R. Fuerte-Esquivel, and H. Ambriz-Perez., FACTS: Modeling and Simulation in Power Networks, London, U.K.: Wiley, 2004.
- [10] S.S Darly, P. R. Vanaja and B. R. Justus, “Modeling, Simulation and Fault Diagnosis of IPFC using P.E.M.F.C for High Power Applications, “Journal of Electrical Engineering Technology, Vol. 8, No. 4: ppg. 760-765, 2013
- [11] L. Jebaraj, C. Christofer Asir and Rajan, S. Sakthivel, “Incorporation of SSSC and SVC Devices for Real Power and Voltage stability Limit Enhancement through Shuffled Frog Leaping Algorithm under Stressed Conditions” in European Journal of Scientific Research ISSN 1450-216X Vol.79 No.1 (2012), pp.119- 132.
- [12] Chintan R Patel, Sanjay N Patel-and Dr. Axay J Mehta, “Static Synchronous Series Compensator (SSSC): An approach for reactive power compensation for the transmission system” in National Conference on Recent Trends in Engineering & Technology.
- [13] K.R. Padiyar “FACTS controller in power transmission and distribution”
- [14] K. K. Sen: “SSSC –static synchronous series compensator: theory, modeling, and applications”, IEEE press 1998.
- [15] R. Mohan and R.K. Varma, “Thyristor-based FACTS Controller for electrical transmission system”, IEEE press, 2002.
- [16] A.H. Norouzi and A.M. Sharaf, “Two control schemes to enhance the dynamic performance of the STATCOM and SSSC”, IEEE Trans.

- Power Del.,vol.20.1,pp.435- 442, Jan, 2005.
- [17] L.Sunil Kumar and A.Ghosh, "Modeling and control design of stastic synchronous series compensator", IEEE Trans. Power Del., vol, no. 4, pp. 1448-1453. Oct, 1999.
- [18] [18] E. Acha, C. Fuerte-Esquivel, H. Ambriz-Perez and C. Angeles-Camacho. FACTS Modelling and Simulation in Power Networks, John Wiley & Sons LTD, England, 2004.
- [19] R. Mohan Mathur and R. K. Varma. Thyristor-based FACTS Controllers for Electrical Transmission Systems, IEEE Series on Power Engineering, US, 2002.
- [20] J. Chow, J.Sanchez-Gasca, H. Ren and Sh. Wang. Power System damping Controller Design Using Multiple Input Signals. IEEE Control Systems Magazine, Volume 20, 82-90, August 2000.

\* \* \* \* \*