



# International Journal of Modern Engineering and Research Technology

Website: <http://www.ijmert.org>

Email: [editor.ijmert@gmail.com](mailto:editor.ijmert@gmail.com)

## Assessment of Voltage Stability Using PV Curve

**Om Prakash Agrawal**

*M. Tech. Research Scholar*

*Takshshila Institute of Engineering & Technology  
Jabalpur (M.P.) [INDIA]*

*Email: [vision\\_om24@gmail.com](mailto:vision_om24@gmail.com)*

**Pramod Dubey**

*Assistant Professor*

*Department of Electrical & Electronics Engineering  
Takshshila Institute of Engineering & Technology  
Jabalpur (M.P.) [INDIA]*

*Email: [pramoddubey@takshshila.org](mailto:pramoddubey@takshshila.org)*

### ABSTRACT

*It is becoming increasingly important for power system planning and operating engineers to be capable of performing comprehensive voltage stability analyses of the systems. This need is largely due to the recent trends towards operating systems under stressed conditions—as a result of increasing system loads without sufficient transmission and/or generation enhancements. There have been many failures, due to voltage instability in power systems around the world. In recent years many researchers have suggested techniques for voltage stability analysis considering both static and dynamic aspects. This paper is mainly concerned with analysis of steady state voltage stability. A method to compute voltage collapse proximity based on PV curve has been done for proximity to voltage stability.*

**Keywords:**— *Voltage Stability analysis, load flow, PV curve, IEEE 6 bus System, Voltage collapse.*

### I. INTRODUCTION

The continuing interconnections of bulk power systems, brought about by economic and environmental pressures, have led to an increasingly complex system that must operate even closer to the limits of stability. The operating environment has contributed to the growing importance of the problem

associated with the static and dynamic stability assessment of power systems. To a large extent this is also due to the fact that most of the major power system breakdowns are caused by problems relating to the system's static, as well as dynamic, responses [6,7]. It is believed that a new type of instability emerges as the system approaches the limits of stability. One type of system instability which occurs when the system is heavily loaded is voltage collapse. This event is characterized by a slow variation in the system operating point, due to increase in the loads; in such a way that the voltage magnitudes gradually decrease until a sharp accelerated change occurs.

It is interesting to note that prior to the sharp change in voltage magnitudes, bus angle and frequency remain fairly constant, a condition observed in several collapses. During a collapse, voltage control devices, such as tap changing transformers, may not be activated if the voltage magnitudes prior to undergoing the sharp change lie in a 'permissible range' and, after the change occurs, the fast rate of the change trips under-voltage relays before the transformers can respond to it. Furthermore, control center operators observe none of the classical advance warning since the bus angle, frequency and voltage magnitude remain normal until large changes in the system state cause protective equipment to

begin to dismantle the network. There has been significant debate over whether voltage collapse problem is static in nature and can therefore be studied as a parametric load flow problem or whether it is dynamic and must be studied as the trajectory of a set of differential equations. Most of the work on this problem to date has been focused on the static problem such as load flow feasibility, optimal power flow and steady state stability [1–3]. The static voltage stability problem has been studied as a static bifurcation characterized by the disappearance of an equilibrium point and how bifurcation could describe instability both in voltage and angle. The power system equilibrium equations typically depend on a very large number of parameters. Moreover, the number of parameters differs from system to system and from time to time. The essential problem of the analysis of power system stability is to recognize impending change in system behavior as these parameters vary and to identify the controlling parameters. In general, loads are dependent on bus voltage. Also, it is known that load dynamics greatly affect the voltage stability. Some researchers have considered only constant P, Q loads that are independent of bus voltage. Since voltage dependent loads play a very important role in voltage stability, more suitable constraints must be considered. The static voltage stability is primarily associated with the reactive power support. The real power (MW) loadability of a bus in a system depends on reactive power support that the bus can receive from the system. Several analytical tools have been presented in the literature for the analysis of the static voltage stability of a system. This paper is mainly concerned with analysis and enhancement of steady state voltage stability based on PV Curve. A load flow is done by using NR method. IEEE 6 bus system is used for simulation.

## II. STATIC VOLTAGE STABILITY ANALYSIS

This section gives a brief outline of some methods for static voltage stability analysis.

### PV curves

The PV curves represent the voltage variation with respect to the variation of load reactive power. This curve is produced by a series of load flow solutions for different load levels uniformly distributed, by keeping constant the power factor. The generated active power is proportionally incremented to the generator rating or to the participating factors which are defined by the user. The P and Q components of each load can or cannot be dependent of the bus voltage accordingly to the load model selected. The determination of the critical point for a given load increment is very important because it can lead to the voltage collapse of the system. These characteristics are illustrated in figure .

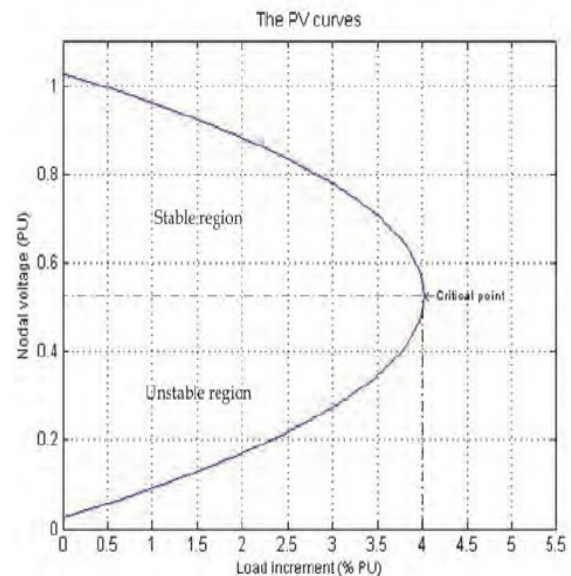

Figure 1: PV Curve

### Sensitivity indices

Some investigators have used the following sensitivity indices for identifying voltage critical buses in the system.

The change in the voltage magnitude of a bus for a given change in the active power loading of the bus.

The net change in the generator reactive power injections for a given change in the reactive power injection at the bus under consideration.

The above indices are computed for the bus under consideration at an operating point by performing the load flow studies. Tolerances are specified for the above indices. If the values of the indices are higher than the specified tolerances, the bus is considered to be voltage critical. This method requires one load flow solution for each bus under consideration.

#### Bus types in load flow studies

**Generator node PV:** It is any node where a generator is connected; the magnitude voltage and generated active power can be controlled or specified, while the voltage phase angle and the reactive power are the unknown state variables [4]

**Load node PQ:** It is any node where a system load is connected; the active and reactive consumed powers are known or specified, while the voltage magnitude and its phase angle are the unknown state variables to be calculated [4]

**Slack node (Compensator):** In a power system at least one of the nodes has to be selected and labeled with this node type. It is a generating node where it cannot be specified the generated active power as in the PV node, because the transmission losses are not known beforehand and thus it cannot be established the balance of active power of the loads and generators. Therefore this node compensates the unbalance between the active power between loads and generating units as specified in the PQ and PV nodes [4].

### III. NEWTON-RAPHSON LOAD FLOW

A power flow or load flow program computes the voltage magnitude and angle at each bus in a power system under balanced three phase steady state conditions. Once they are calculated, real and reactive power flows for all equipment interconnecting the buses, as well as *equipment losses* are also computed. There are two ways to represent the bus voltage equations to solve the Newton-Raphson load flow problem. Most references use rectangular coordinates of bus voltages. [12, 13, 14]. We prefer to use polar coordinates of bus voltage as it will be implemented in the Matlab simulation program developed. Consider first the non-linear equation  $y = f(x)$

$$x = \begin{bmatrix} \delta \\ V \end{bmatrix} = \begin{bmatrix} \delta_1 \\ \delta_N \\ V_1 \\ V_2 \\ \vdots \\ V_N \end{bmatrix}; y = \begin{bmatrix} P \\ Q \end{bmatrix} = \begin{bmatrix} P_1 \\ P_N \\ Q_1 \\ Q_2 \\ \vdots \\ Q_N \end{bmatrix}; f(x) = \begin{bmatrix} P(x) \\ Q(x) \end{bmatrix} = \begin{bmatrix} P_1(x) \\ \vdots \\ P_N(x) \\ Q_1 \\ \vdots \\ Q_N(x) \end{bmatrix}$$

where  $V$  (voltage),  $P$  (real power) and  $Q$  (reactive power) terms are given in per unit and  $\delta$  (phase angle) terms are in radians. The swing bus variables  $\delta_1$  and  $V_1$  are omitted from Equation [1] because they are already known. This equation shows that the real and reactive powers at every bus except the slack bus can be expressed as a function of voltage magnitude and phase angles. The outputs of Newton-Raphson load flow algorithm which give the voltage levels at each bus, power flow in the line connecting two buses in either direction

#### Voltage collapse

The voltage collapse is a phenomenon that might be present in a highly loaded electric power system. This can be present in the

form of event sequence together with the voltage instability that may lead to a blackout or to voltage levels below the operating limits for a significant part of the power system (5). Due to the nonlinear nature of the electrical network, as the phenomenon related to the power system, it is necessary to employ nonlinear techniques for the analysis of the voltage collapse (9) and find out a solution to avoid it. There many disturbances which contribute to the voltage collapse:

**Load increment.**

- To reach the reactive power limits in generators, synchronous condensers or SVC.
- The operation of TAP changers in transformers.
- The tripping of transmission lines, transformers and generators.

Most of these changes have a significant effect in the production, consumption and transmission of reactive power. Because of this, it is suggested control actions by using compensator elements as capacitor banks, blocking of tap changers, new generation dispatch, secondary voltage regulation and load sectioning (5).

**IV. RESULT AND DISCUSSION**

A Matlab load flow simulation program has been developed using a modified Newton-Raphson algorithm to calculate and control the voltage, to increase the loading use the multiplying factor and determine real and reactive power flows and compute real power losses. Voltage control using tap changers can be implemented in the load flow analysis and PV curve is plotted to know the voltage stability margin at test bus no 3.

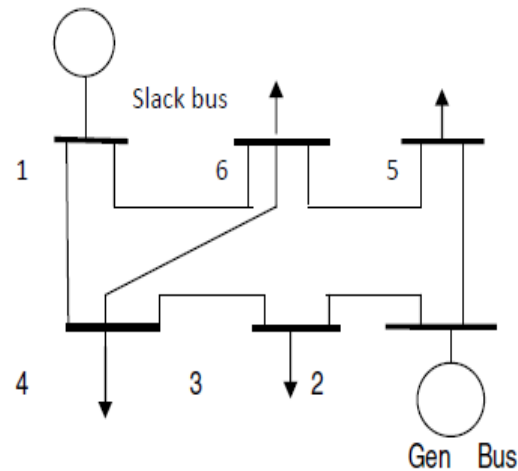

Figure 2 : IEEE 6 Bus Test system

**Table 1 : Line Data for IEEE 6 Bus Test System**

Line No.	From Bus	To Bus	R	X	B/2 (p.u.)	Off nominal tap ratio in case of transformer
1	1	6	0.1421	0.5183	0	0
2	1	4	0.08503	0.41209	0	0
3	4	6	0.12682	0.43134	0	0
4	6	5	0	0.3016	0	0
5	5	2	0.32623	0.67223	0	0
6	2	3	0.77092	1.07475	0	0
7	4	3	0	0.13697	0	0

**Table 2 : Bus Data for IEEE & Bus Test System**

Bus No.	Type of Bus	Bus Voltage	Angle	Active Power Loading	Reactive Power Loading	Active Power Generating	Reactive Power Generating
1	Slack Bus	1	0	0	0	0.45	0.06
2	Gen Bus	1	0	0	0	0.5	0.2
3	Load Bus	1	0	0.275	0.065	0	0
4	Load Bus	1	0	0	0	0	0
5	Load Bus	1	0	0.15	0.09	0	0
6	Load Bus	1	0	0.25	0.005	0	0

**Table : 3 Load Flow Result**

Load Multiplying factor	Bus Voltage	Angle	Active Power Loading	Reactive Power Loading
0	0.976	-0.992	0	0
0.1	0.972	-1.611	0.028	0.007
0.2	0.968	-2.236	0.055	0.013
0.3	0.964	-2.866	0.083	0.02
0.4	0.96	-3.503	0.11	0.026
0.5	0.955	-4.147	0.138	0.033
0.6	0.951	-4.797	0.165	0.039
0.7	0.946	-5.456	0.193	0.045
0.8	0.941	-6.122	0.22	0.052
0.9	0.936	-6.798	0.248	0.059
1	0.931	-7.483	0.275	0.065
1.1	0.926	-8.178	0.303	0.072
1	0.92	-8.884	0.33	0.078
1.3	0.914	-9.601	0.358	0.085
1.4	0.908	-10.331	0.385	0.091
1.5	0.902	-11.075	0.413	0.098
2	0.868	-15.048	0.55	0.13
2.5	0.825	-19.634	0.688	0.163
3	0.767	-25.403	0.825	0.195
3.5	0.657	-35.418	0.963	0.228

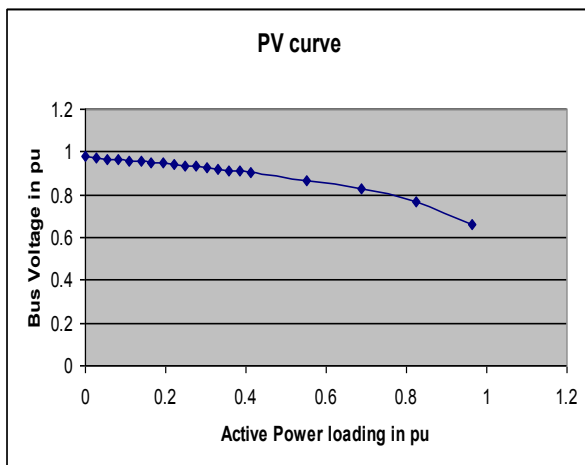

Figure 3 : PV Curve Bus Voltage and Active Power Loading in pu

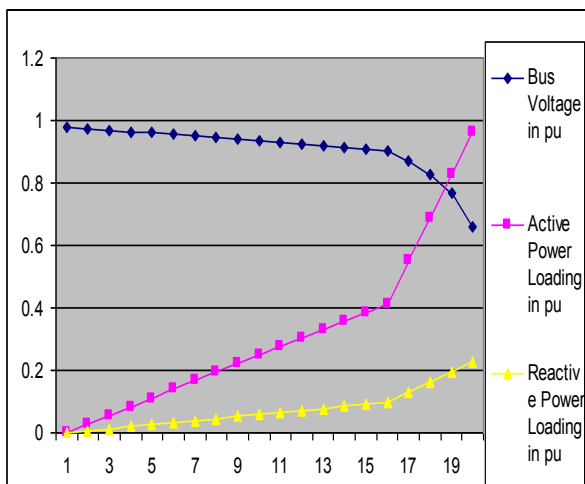

Figure : 4 Active Power, Reactive Power, Bus Voltages

**REFERENCES:**

- [1] B.M. Weedy, B.R. Cox, Voltage stability of radial power links, Proc. IEE 115 (4) (April 1968).
- [2] T. Naagao, Voltage collapse at load ends of power systems, Electr. Eng. Jpn 95 (4) (1975).
- [3] V.A. Venikov, V.A. Stroeve, V.I. Idelchick, V.I. Tarasov, Estimation of electrical power steady state stability in load flow calculations, IEEE Trans. Power Appar. Syst. 94 (May:June1975) 1034–1041.
- [4] Arrillaga, J. & Walsion, N. (2001). *Computer Modeling of electrical Power Systems (2th)*, Wiley, ISBN 0-471-87249-0.
- [5] Kundur, P. (1994). *Voltage Stability, Power System stability and control*, pp. 959-1024, Mc Graw Hill, ISBN 0-07-035959-X, Palo Alto, California
- [6] A. Tiranuchit, R.J. Thomas, A posturing strategy against voltage instabilities in electric power systems, IEEE Trans. Power Syst. 3 (1) (February 1988) 87–93.
- [7] IEEE committee report on voltage stability of power systems: Concepts, analytical tools and industry experience IEEE:PES publication 90TH0358–2 PWR.
- [8] P.A. Lof, G. Anderson, D.J. Hill, Fast calculation of a VS index, PES winter meeting, New York, NY, February 3–7 (1991).
- [9] Venkataramana, A. (2007). *Power Computational Techniques for Voltage Stability Assessment and Control (1th)*, Springer, ISBN 978-0-387-26080-8.



- [10] P.A. Lof, G. Anderson, D.J. Hill, Voltage stability indices for stressed power systems, IEEE Trans. Power Syst. 8 (1) (February 1993).
- [11] H.K. Clark, New challenges: Voltage stability, IEEE Power Eng. Rev. (April 1990) 33–37.
- [12] Stevenson, W.D. 1975, *Elements of Power System Analysis*, 3rd ed., McGraw-Hill Kogakusha, Ltd., Tokyo.
- [13] Stagg, G.W. and El-Abiad, A.H. 1968, *Computer Methods in Power System Analysis*, McGraw-Hill Book Company, New York.
- [14] Weedy, B.M. and Cory, B.J., 1998, *Electric Power Systems*, 4th ed., John Wiley & Sons, West Sussex.

\* \* \* \* \*