



Implementation of Static Synchronous Series Compensator for Power Flow Improvement in Electrical Power Transmission System

Vaishali Pandey

*M.Tech. Research Scholar
Energy Technology
Takshshila Institute of Engineering and Technology
Jabalpur, (M.P.) [INDIA]
Email: pp2739@gmail.com*

Pramod Dubey

*Assistant Professor
Computer Science & Engineering
Takshshila Institute of Engineering and Technology
Jabalpur, (M.P.) [INDIA]
Email: pramoddubey@takshshila.org*

ABSTRACT

During this study, a static synchronous series compensator (SSSC) is employed to dominant active and reactive powers still as damping grid oscillations in transient mode. For quick power flow management within the cable system this reducing the effective electrical phenomenon of lines by series compensation may be a direct approach to extend transmission power capability. But power transfer capability of long transmission lines is proscribed by stability thought. The SSSC with a supply of energy within the DC link will provide or absorb the reactive and active power from the road. Complete Simulations are worn out MATLAB/SIMULINK atmosphere. Simulation result shows the accuracy of planned compensator and achieving the required price for active and reactive powers, and damping of oscillations.

Keywords:— *Cable, Power oscillation damping, Static Synchronous Series compensator (SSSC), Active and Reactive power*

I. INTRODUCTION

An inherent characteristic of electric energy transmission and distribution by alternating current (AC) is that real power is generally associated with reactive power. Distribution

lines and AC transmission are reactive power networks that are characterized by their per-Kilometer series inductance and shunt capacitance [2]. As load power factor changes the transmission lines voltage profile change that can cause large change amplitude variations in the receiving end voltage. Voltage degradation is affect in the performance of loads. The Over voltage is causes harmonic generation and magnetic saturation in system equipment is cause insulation breakdown [4]. After any disturbance of the system Power system has ability to regain its original operating condition. Power system transient stability analysis is generation or transmission system due to fault or switching [1]. Reactive power compensation has identified as a very key measure to improve the transient stability of the system. For increasing system stability margin gain Flexible AC Transmission Systems (FACTS) devices provides suitable control strategy. Static Synchronous Series compensator (SSSC) is a member of FACTS family which is connected in series with a power system [1]. It is consists solid state Voltage Source Converter (VSC) which generates a controllable alternating current voltage at fundamental frequency. While the primary purpose of a SSSC is to control power flow in steady state also

improves transient stability of a power system.

Static Synchronous Series Compensator

The Static Synchronous Series Compensator (SSSC) is a series type FACTS controller based on Voltage Source Compensate [3]. A SSSC has several advantages over a TCSC such as elimination of passive components; improve technical system characteristics, symmetric capability in both inductive and capacitive operating modes, and possibility of connecting an energy source on the DC side to exchange real power with the AC network.

Operation of SSSC and the Control of Power Flow

The Static Synchronous Series Compensator (SSSC) is one of series FACTS devices. SSSC is a solid-state voltage source inverter, injects a nearly sinusoidal voltage, with variable magnitude in series with the transmission line. The injected voltage is in quadrature with the line current that provides the losses in the inverter. The injected voltage, which is in quadrature with the line current, follows an inductive or a capacitive reactance in series with the transmission line [6]. This variable reactance, inserted by the injected voltage source and the electric power flow through the transmission line. Schematic of a SSSC and the equivalent circuit of the SSSC is shown in Figure 1. Regulation of power flow can control with control the magnitude of V_c . The winding resistance and leakage reactance of the connecting transformer appear is series with the voltage source V_c . If there is no energy source on The DC side, neglecting losses in DC capacitor and the converter, the power balance in steady state. Equation (1.1) V_c is in quadrature with current I . If V_c lags I by 90, the operating mode is capacitive and the current (magnitude) in the line is increased with

resultant increase in power flow [8]. On the other hand, if V_c leads I by 90, the operating mode is inductive, and the line current is decreased. Note that we are assuming the injected voltage is sinusoidal (neglecting harmonics).

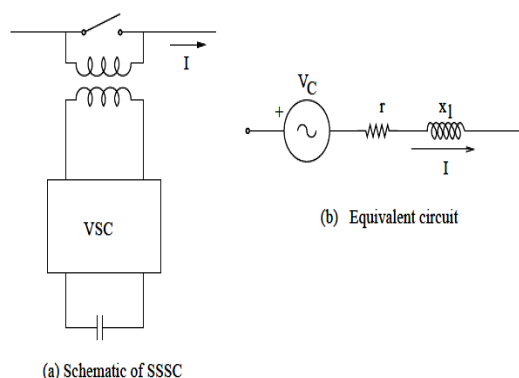

Figure 1. Schematic of SSSC. [2]

Since the losses are always present, the phase shift between current and V_c is less than 90 (in steady state). In general, it can be written as

$$Re[V_c I^*] = 0 \dots\dots\dots(1)$$

$$V_c = V_c(\cos \gamma - j \sin \gamma)e^{j\Phi} \dots\dots\dots(2)$$

Equation (1.2) where Φ is the phase angle of the line current, γ is the angle by which lags the current. V_{cp} and V_{cr} are the in-phase and quadrature components of the injected voltage (with reference to the line current) [10]. We can also term them as active (or real) and reactive components. The real component is required to meet the losses in the converter and the DC capacitor.

II. METHODOLOGY

A Static Synchronous Series compensator (SSSC) is a member of FACTS family which is connected in series with a power system. It consists of a solid state Voltage Source Converter (VSC) which generates a controllable alternating current and voltage at fundamental frequency. When the voltage

injected is kept in quadrature with the line current, it can follow as inductive or capacitive reactance so as to influence the power flow through the transmission line [11]. While the primary purpose of a SSSC is to control power flow in steady state and also improve transient stability of a power system. A Static Synchronous Series compensator (SSSC) is used to investigate the effect of this device in controlling active and reactive powers as well as damping power system oscillations in transient mode. The SSSC set with a source of energy in the DC link can supply or absorb the reactive and active power from or to the line. Simulations have been done in MATLAB/SIMULINK environment. Simulation results shows for selected bus-2 in three phase 500 KV transmission line system shows the accuracy of this compensator [17]. FACTS devices member in controlling power flows, achieving the desired value for reactive and active powers, and damping oscillations appropriately. The methodology of this paper is shown in the figure 2 with the help of simulink diagram representation. The description of each block in the above figure is as follows:

1. **Three Phase Source** – The three phases block supplies 500KV three phase voltage to the transmission line.
2. **Three phase fault generator** — This block generator fault on the transmission line according to user specification.
3. **B1 Bus** — This bus indicates interfacing connection between 500 KV 2100 MVA source and SSSC block and also provides Voltage(V) & Current (I) measurement.
4. **Static Synchronous Series Compensator (SSSC) Block** — This

block represents the SSSC simulation model for the project work.

5. **B2 Bus**—This bus indicates interfacing connection between SSSC block and 280 KM line and also provides Voltage(V), Current(I) measurement. 280 Km Line – this block represents 280 KM transmission line.
6. **Three Phase Dynamic Load**—Represents load at the end of transmission si de.
7. **150 Km Line** — This block represents 150 KM transmission li ne.
8. **B4 Bus**—this bus indicates interfacing connection between 150 KM line to next 150 KM lin e.
9. **B3 Bus**—this bus indicates interfacing connection between 50 KM line and dynamic lo ad.

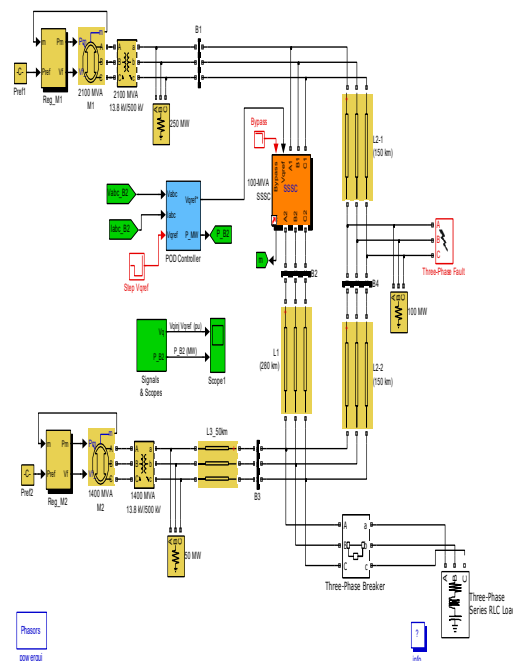

Figure 2: Simulink diagram representation of proposed work.

III. RESULTS AND DISCUSSIONS

SSSC with POD Controller the facility grid consists of 2 power generation substations and one major load center at bus B3. the primary power generation station (M1) encompasses a rating of 2100 MVA; representing half dozen machines of 350 MVA and also the alternative one (M2) encompasses a rating of 1400 MVA, representing four machines of 350 MVA.

1. SSSC Dynamic Response

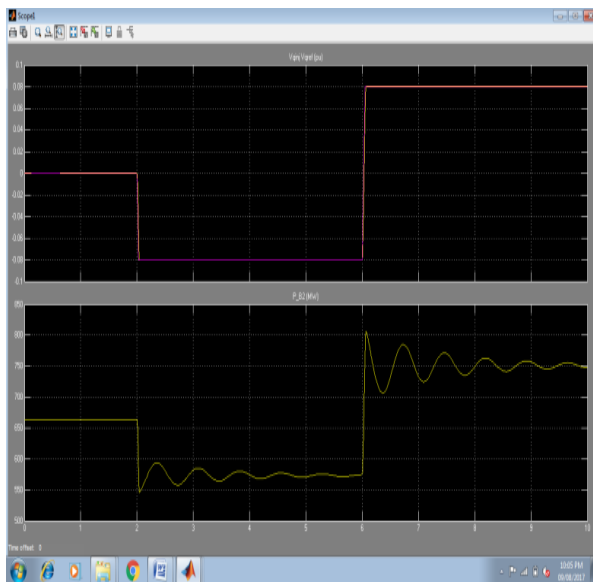

Figure 3: illustrates, the facility obtained at bus B2 while not SSSC.

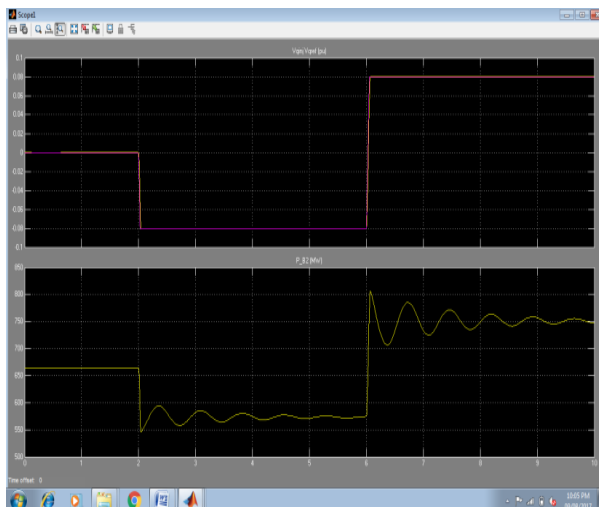

Figure 4: Facility obtained in the least the buses B1, B2, B3 and B4 while not SSSC.

When parameter is amendment from three to zero.05. Rerun the simulation. the facility oscillation on the active power ought to currently be terribly little.

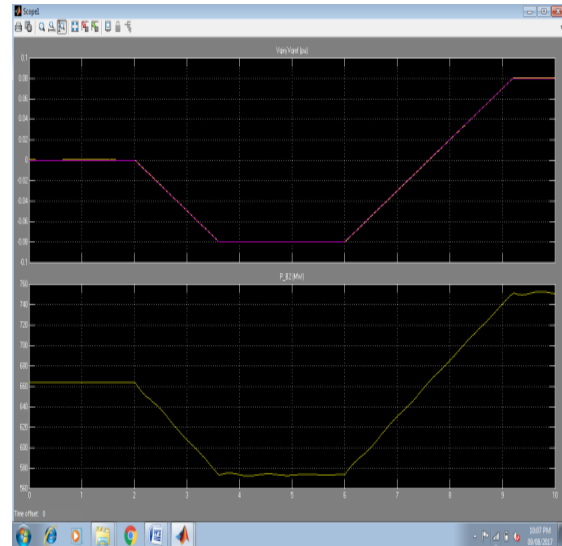

Figure 5: illustrates, the facility obtained at bus B2 while not SSSC.

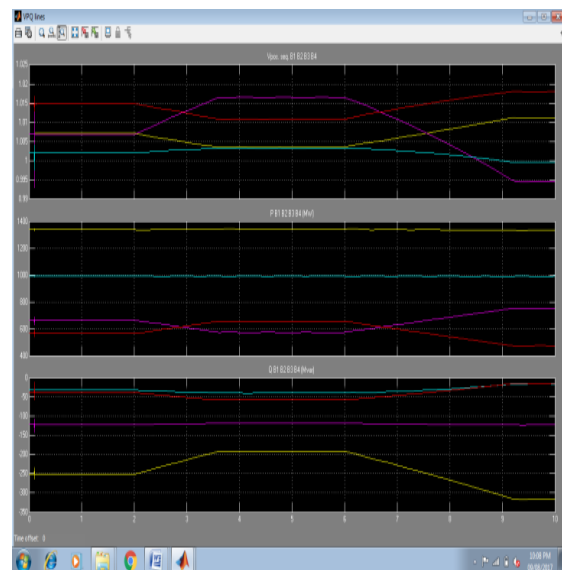

Figure 6: Facility obtained in the least the buses B1, B2, B3 and B4 while not SSSC.

The advancement in the technology like home equipments and plant equipments, demands for precession and highly regulation in the received power from energy generator through the lines, because in current scenario the equipments are very much sensitive to supply power regulation.

Any kind of fluctuation either damage the costly equipment or may harm full for further used equipments. In this paper used algorithm shows an efficient solution of this problem.

IV. CONCLUSION

The advancement in the technology like home equipments and plant equipments, demands for precession and highly regulation in the received power from energy generator through the lines, because in current scenario the equipments are very much sensitive to supply power regulation. Any kind of fluctuation either damage the costly equipment or may harm full for further used equipments. In this paper used algorithm shows an efficient solution of this problem. In this paper, a Static Synchronous Series compensator (SSSC) is has been investigated to analyze the effect of this device in controlling active and reactive powers as well as damping power system oscillations in transient mode. The SSSC setup with a source of energy in the DC link can supply or absorb the reactive and active power to or from the line.

REFERENCES:

- [1] N. G. Hingorani and L. Gyugyi, "Understanding FACTS concepts and Technology of flexible AC transmission systems", New York. IEEE Press, 2000.
- [2] E.Acha., H Ambriz-Perez and Fuerte-Esquivel "Advanced SVC Models for Newton-Raphson Load Flow and Newton Optimal Power Flow Studies", IEEE Transactions on Power Systems, Vol. 15(1), p.129-136, 2000.
- [3] L Cai "Robust Co-ordinated Control of FACTS Devices in Large Power Systems" a PhD Thesis, University of Duisburg, Germany, published by Logos Verlag Berlin, 2004.
- [4] T. Orfanogianni and R. Bacher. "Steady-state optimization in power systems with series FACTS devices", IEEE Transactions on Power Systems, Vol. 18(1), pp.19–26, 2003.
- [5] B.H. Kim and R. Baldick. "A comparison of distributed optimal power flow algorithms", IEEE Transactions on Power Systems, Vol. 15(2), pp. 599–604, 2000. International Journal of Engineering Research & Technology
- [6] B. Singh, K.S. Verma, P. Mishra, R. Maheshwari, U. Srivastava and A. Baranwal, "Introduction to FACTS Controllers: A Technological Literature Survey", International Journal of Automation and Power Engineering, Volume 1 Issue 9, website: www.ijape.org December 2012
- [7] T. Bhaskaraiah and G. U. Reddy, "Power system stability enhancement using static synchronous series compensator (SSSC)", International Journal of Electrical, Electronic and Telecommunications, ISSN 2319 – 2518, www.ijeetc.com, Vol. 2, No. 1, January 2013
- [8] M. Ahsan, A. Murad, F. J. Gómez and L. Vanfretti, "Equation-Based Modeling of FACTS using Modelica", July 2013
- [9] E. Acha, C. R. Fuerte-Esquivel, and H. Ambriz-Perez., FACTS: Modeling and Simulation in Power Networks, London, U.K.: Wiley, 2004.
- [10] S.S Darly, P. R. Vanaja and B. R. Justus, "Modeling, Simulation and Fault Diagnosis of IPFC using P.E.M.F.C for High Power Applications, "Journal of Electrical

- Engineering Technology, Vol. 8, No. 4: ppg. 760-765, 2013
- [11] L. Jebaraj, C. Christober Asir and Rajan, S. Sakthivel, "Incorporation of SSSC and SVC Devices for Real Power and Voltage stability Limit Enhancement through Shuffled Frog Leaping Algorithm under Stressed Conditions" in European Journal of Scientific Research ISSN 1450-216X Vol.79 No.1 (2012), pp.119- 132.
- [12] Chintan R Patel, Sanjay N Patel and Dr. Axay J Mehta, "Static Synchronous Series Compensator (SSSC): An approach for reactive power compensation for the transmission system" in National Conference on Recent Trends in Engineering & Technology.
- [13] K.R.Padiyar "FACTS controller in power transmission and distribution"
- [14] K.K. Sen: "SSSC–static synchronous series compensator: theory, modeling, and applications", IEEE press 1998.
- [15] R. Mohan and R.K. Varma, "Thyristor-based FACTS Controller for electrical transmission system", IEEE press, 2002.
- [16] A.H. Norouzi and A.M. Sharaf, "Two control schemes to enhance the dynamic performance of the STATCOM and SSSC", IEEE Trans. Power Del., vol.20.1, pp. 435-442, Jan, 2005.
- [17] L.Sunil Kumar and A.Ghosh, "Modeling and control design of stastic synchronous series compensator", IEEE Trans. Power Del., vol, no. 4, pp. 1448-1453. Oct, 1999.
- [18] E. Acha, C. Fuerte-Esquivel, H. Ambriz-Perez and C. Angeles-Camacho. FACTS Modelling and Simulation in Power Networks, John Wiley & Sons LTD, England, 2004.
- [19] R. Mohan Mathur and R. K. Varma. Thyristor-based FACTS Controllers for Electrical Transmission Systems, IEEE Series on Power Engineering, US, 2002.
- [20] J. Chow, J.Sanchez-Gasca, H. Ren and Sh. Wang. Power System damping Controller Design Using Multiple Input Signals. IEEE Control Systems Magazine, Volume 20, 82-90, August 2000.
- [21] I. Kamwa, R. Grondin and L. Loud. Wide-Area Measurement Based Stabilizing Control of Large Power Systems - A Decentralized/ Hierarchical Approach, IEEE Transactions on Power Systems, Vol. 16, No. 1, February 2001, 136-153.

* * * * *